



Plug & Seal

Fast-fit plug Connections for
Housings, Pipe Ends and Assemblies

simrit[®]

Simrit® , Your Global Technology Specialist for Seals and Vibration Control

Simrit, Your Global Technology Specialist for Seals and Vibration Control offers you a complete service package. A unique range of products and services guarantees you numerous advantages over the competition.

Simrit acts as a partner to general industry. Its position as a market leader is achieved through continuous research, development and manufacture. We have the world's widest range of seals and vibration control products, and can offer you solutions based on the demands of state-of-the-art-technology, solutions which set standards.

This way we secure competitive advantages for you based on experience all around the world: Simrit has a presence throughout Europe, America and Asia, either directly or through its affiliated companies NOK (Japan) or Freudenberg-NOK (USA). The transfer of knowledge between these markets is incorporated directly into the Simrit service package.

With our many Simrit Service Centres and Simrit distribution Partners, we serve and supply more than 100,000 customers worldwide. Our Simrit Partners ensure rapid availability from stock. This means spare parts quickly arrive when and where they are needed. There is a Simrit Partner near you as well.

Make the most of Simrit's service package and give yourself a real competitive edge:

- + Constant innovations
- + Uniquely wide range of products
- + Strong product brands
- + Unique materials expertise
- + A wide range of value added services

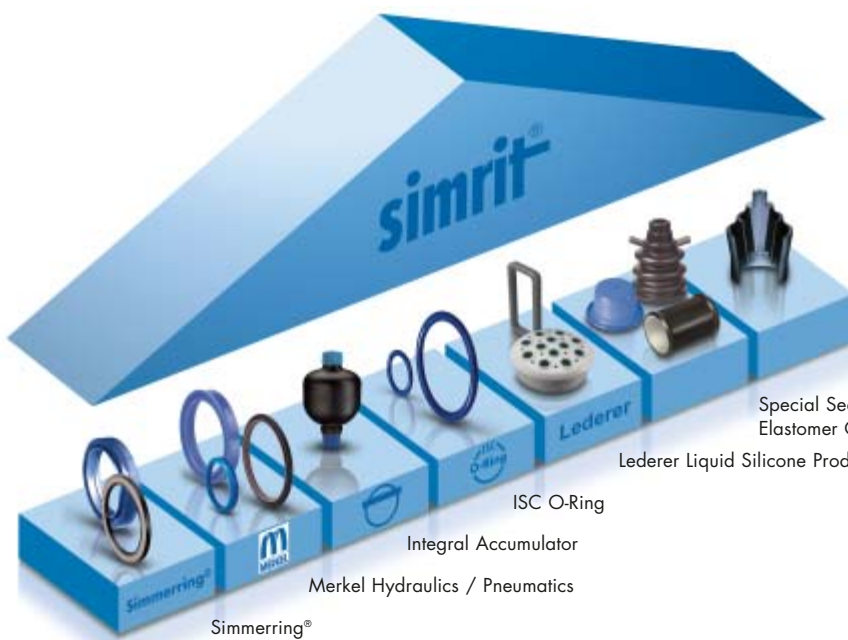

Simrit offers a complete package of products and services, including leading brands such as Simmerring®, Merkel, Integral Accumulator, Meillor and ISC O-Ring.

Special Sealing Products: Bellows, Diaphragms, Elastomer Composite Parts and Precision Mouldings

Lederer Liquid Silicone Products

Vibration Control

ISC O-Ring

Integral Accumulator

Merkel Hydraulics / Pneumatics

Simmerring®

Overview of Plug & Seal

Simrit has brought about a marked improvement in the connection of two housings for the transport of media. With Plug & Seal plug connections safety shortcomings in terms of tightness or high fitting costs with alternative competitor solutions can be avoided.

Simple design

Plug & Seal plug connections are designed as pipe sections rubber-coated on the outside with sealing beads and shock absorbers. They are used to create a leakfree connection between two housings or units – to ensure the safe transport of media such as oils, water or air. Beside standard-design Plug & Seal Simrit also offers individual product solutions which are tailored to specific customer requirements.

Overview of benefits

Plug & Seal plug connections from Simrit

- create a reliable seal including with high pressures
- give simple, secure and low-cost fitting
- ensure acoustic and mechanical decoupling
- minimise maintenance costs due to a greatly improved service life
- compensate for misalignment and permit greater tolerances on installation
- reduce logistics costs
- combine several functions in a single component
- offer clear benefits through lower total cost.

Simple to replace

Plug & Seal plug connections offer a wide range of benefits and help to do away with inadequate substitution solutions. This includes:

- cast-iron pipe with turned grooves
- machined aluminium pipe with two fitted O-Rings (Fig. 2)
- hose with hose-clips
- gasket or O-Ring seal.

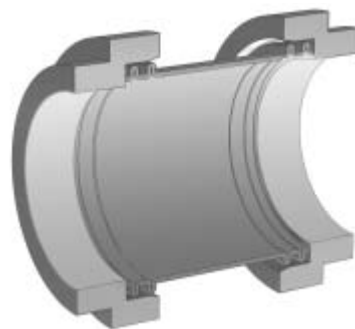
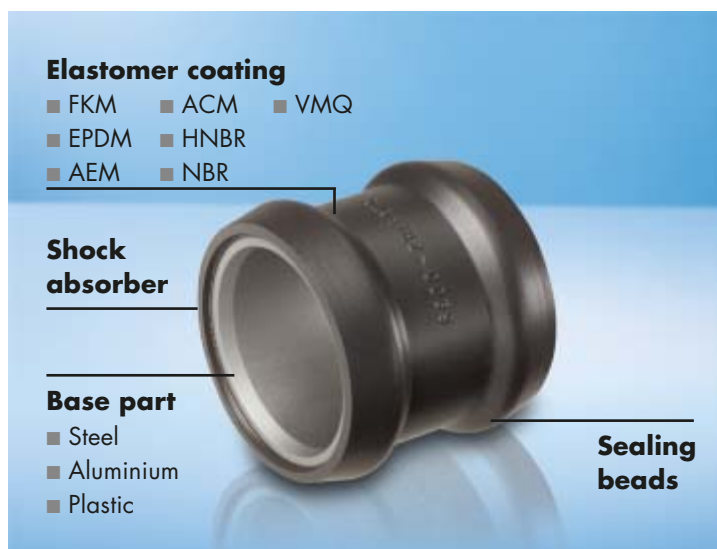

Fig. 2: Machined aluminium pipe



Selection of materials

Rubber coatings and shock absorption are available with modern elastomer materials – for a range of different physical requirements. You are also free to choose the base material of the pipe section: steel, aluminium or plastic. Thanks to the flexible range of materials the plug connections can be used in virtually all sectors of fluids and gas transport.



Examples of applications for special purposes

There is an enormous range of possible applications for Plug & Seal plug connections from Simrit. They offer an optimum solution in many branches of industry.

Wide range of applications

Plug & Seal plug connections are used in areas such as the following:

- in water and oil circuits or in air routing systems of internal combustion engines
- in ancillary engine components such as superchargers, turbochargers or intake manifolds
- in automatic/manual transmission systems
- in valve and pipework systems
- in heating and air-conditioning systems of installations and buildings.



Plug & Seal in engines and ancillary components

In turbo diesel engines the turbocharger needs a reliable supply of charge air. Here the use of Plug & Seal between the air supply and the charge air pipe guarantees a secure leak-free connection. The elastomer component of the Plug & Seal plug connection is made of FKM and is temperature-resistant to 220 °C.

With this application it is above all compensation of the offset that makes Plug & Seal so advantageous.

In addition, with modern diesel engines it is possible to comply with tighter limit values of future exhaust emissions standards thanks to exhaust gas recirculation systems (EGR). The use of Plug & Seal as a connection pipe in an EGR system results in reliable sealing and acoustic decoupling. Here aggressive media and temperatures up to 180 °C make extremely high demands on Plug & Seal. For this reason materials such as FKM and stainless steel are used.



Plug & Seal in transmission systems

In transmission systems of vehicles and machines a continuous oil circuit is necessary. Plug & Seal plug connections can be used here to ensure a reliable oil supply also going beyond the limits of various transmission components. The elastomer component of the Plug & Seal plug connection is made of HNBR and is temperature-resistant to 150 °C. With this application the key benefits of Plug & Seal are extremely secure fitting and reliable life-long sealing.



Plug & Seal in heating systems

If water is to pass through radiators, the individual fins need to be connected to form a circuit by means of a manifold. Plug & Seal fulfils this function safely and reliably. The elastomer component of the Plug & Seal plug connection is made of EPDM and is temperature-resistant to 140 °C. A plastic pipe is used as the base part. For this application it is particularly advantageous that Plug & Seal makes the fitting of radiators simpler, safer and more efficient.



Examples of applications for multifunctionality

For specific customer requirements in terms of multifunctionality Simrit offers customised Plug & Seal product solutions. Thanks to special product design it is possible to combine several specific functions in one component.

Internal/external-sealing Plug & Seal plug connection

Individually adapted internal/external-sealing Plug & Seal plug connections can be used to good effect with the following applications:

- sealing a long or convoluted media route in the engine cooling circuit: pipe with an internal/external-sealing Plug & Seal product at both ends
- seal and decoupling between cooling water manifold and cylinder head in a stationary diesel engine with an internal/external-sealing Plug & Seal product (Fig. 1).

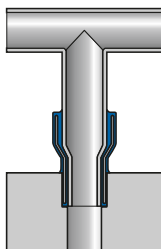

Fig. 1



Plug & Seal for efficient fitting

In practice it is often important to ensure that the fitting of seals and components is simple, safe and effective. These objectives can be achieved with Plug & Seal plug connections:

- Plug & Seal components fix themselves in position in the housing automatically
- simplified overhead fitting
- multiple fitting of all sealing connections in a single operation.

To automate the multiple fitting of Plug & Seal further a chain of linked Plug & Seal components can be created (Fig. 2).

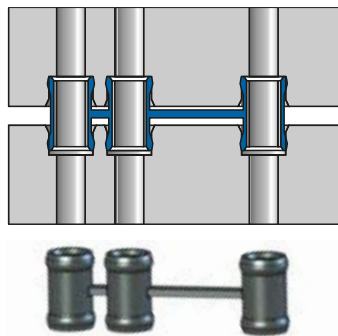

Fig. 2

Plug & Seal with additional function

Innovative and customised design in terms of function is also possible for Plug & Seal plug connections. One example of a Plug & Seal plug connection with an additional function is media routing in the oil cooler of an internal combustion engine (Fig. 3). These functions are performed by the Plug & Seal plug connection:

- leakfree media routing between oil cooler and engine block
- compensation for misalignment
- minimisation of oil level in oil cooler, protection of pipe connection from abrasion due to the elastomer coating.

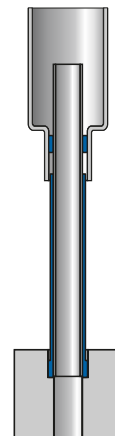

Fig. 3



Technical Benefits

The Simrit brand product Plug & Seal wins over customers with technical benefits such as high pressure resistance including with complex applications.

Reduced requirements on plane parallelism

In practice sealing problems often crop up when connecting housings with uneven surfaces that are not plane-parallel. Plug & Seal offers an appropriate solution here. Unlike O-Ring-solutions the seal requires no direct contact to the housing surfaces; plane parallelism is not essential either (Fig. 1).

Plug & Seal thus provides for greater tolerances, reducing the cost of housing manufacture (Fig. 2).

Acoustic and mechanical decoupling

The statutory provisions for the reduction of noise levels for machines and vehicles become more stringent every year. Particularly when dynamic units or housings are to be connected, the transmission of noise and vibrations is a major problem. With Plug & Seal these effects are eliminated by the plug connections themselves. The elastomer shock absorbers perform acoustic and mechanical decoupling for Plug & Seal.

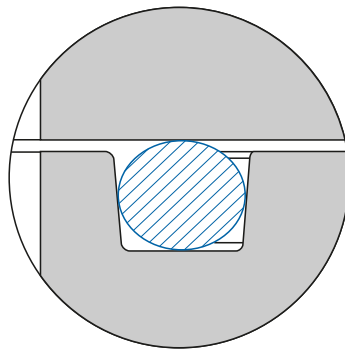

Fig. 1: O-Ring solution

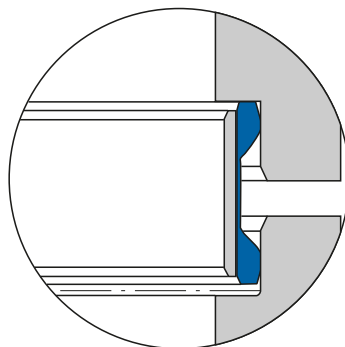
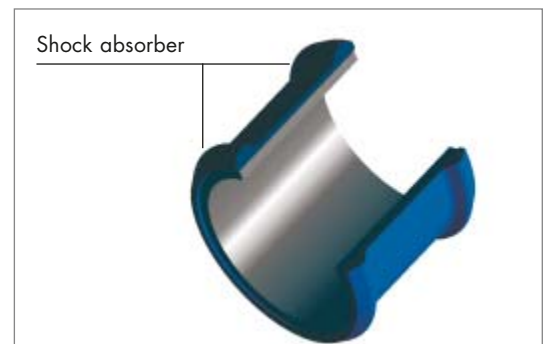

Fig. 2: Plug & Seal



Further Technical Benefits

Compensation of misalignment/offset

With the connection of housings, pipe ends and units it is often necessary to compensate for misalignment. Problems then frequently crop up particularly with substitution solutions involving O-Rings (Fig. 3). Due to

the fit of the metal pipe offset is either not possible or only to a very limited extent. However, with Plug & Seal the sealing contour permits an offset of max. 5 mm (Fig. 4)*. Due to the reduced requirements a marked reduction in manufacturing costs is possible.

Reliable at high pressures

It has been possible to accurately simulate and predict the sealing performance of Plug & Seal at high pressures using FEM calculations (Fig. 5). The results have been confirmed by test series. The most important finding was that as the media pressure increases, the greater the contact stress between the sealing bead of the Plug & Seal component and the installation wall. This results in a sealing effect that increases in parallel (self-reinforcement effect). The max. permissible media pressure for Plug & Seal is currently approx.:

- 10 bar (standard)
- 70 bar (special solution)

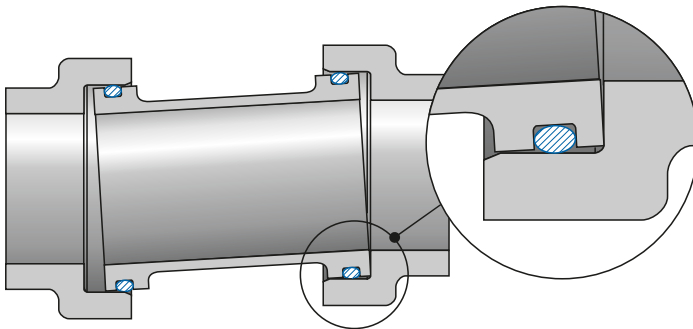

Fig. 3: O-Ring-solution

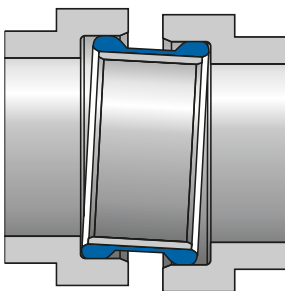

Fig. 4: Plug & Seal



Fig. 5

* Possible offset depends on:

- length and diameter of Plug & Seal plug connection
- depth of housing
- system pressure

There are also economical benefits to Plug & Seal:

Simple, secure and low-cost fitting

Plug & Seal-components can be installed quickly and at low cost. The plug connections fix themselves in position automatically on installation. In addition, several Plug & Seal units can be fitted in a single operation. Automatic fitting is also possible.

Low logistical costs

Compared with many substitution solutions Plug & Seal plug connections have the advantage that they only consist of one component, thus reducing costs in terms of both logistics and fitting.

Long service life

In long-term applications Plug & Seal-solutions last much longer than O-Ring-connections. In comparison their life is 10 to 50% greater. Positive effect: reduced maintenance costs in terms of work time and the materials required. In addition, there is a major reduction in the costs of complaints for failures occurring in the field.

Lower manufacturing costs

Unlike competitor-solutions Plug & Seal is capable of compensating for misalignment up to 2 mm. This provides for greater permissible tolerances with housing manufacture, resulting in a marked reduction in costs.

Clear benefits in a direct cost comparison

The following example of a cost comparison (see table) demonstrates the savings potential available. The Plug & Seal element listed performs additional functions besides leakfree media routing. Special dust lips protect the actual sealing lip from soiling, thus ensuring a long service life (Fig. 1).

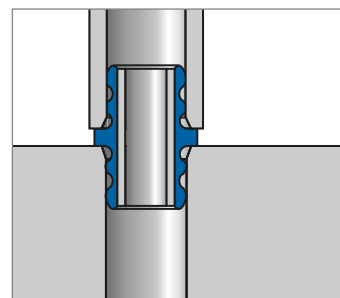

Fig. 1

Example of a cost comparison between Plug & Seal and an O-Ring-solution



Cost position	Costs O-Ring solution (€/piece)	Costs Plug & Seal-solution (€/piece)
1x expensive plastic-base part (incl. refinishing of groove)	0.65	n/a
Plug & Seal complete	n/a	0.70
2x O-Rings EPDM	0.10	n/a
1x moulded part seal EPDM	0.20	n/a
Logistical costs as a function of the number of components	0.15	0.05
Additional costs of housing manufacture (tolerances)	0.05	n/a
Additional fitting costs	0.05	n/a
Reworking due to fitting defects (twisting and damage to O-Rings)	0.15	n/a
Total costs	1.35	0.75

Plug & Seal Standard Variants

To give a cost effective solution for Plug & Seal with low piece numbers, there is a standard programme without additional tool costs.

Product variety

Even the standard programme can offer the right sealing solution for a whole range of applications thanks to its wide variety.

The standard-Plug & Seal plug connections basically consist of a base part in steel and a seal made of the following elastomer materials (see also table on next page):

- EPDM
- FKM
- on request: AEM, ACM, NBR, HNBR, VMQ

The standard dimensions of Plug & Seal cover a wide range of operating conditions (see table below):

- 15 to 40 mm diameter of locating bore
- 20 to 60 mm connection-length

No tool costs

There is a major cost advantage for the Plug & Seal standard variants particularly with a low annual requirement. As in the case of all standard products from Simrit, tool costs are no longer incurred, something that would otherwise have an adverse effect on total costs.



Plug & Seal standard dimensions

External diameter [mm] Plug & Seal (A)*	Locating bore [mm] (acc. to H8) (B)**	Internal diameter pipe [mm] (R1)	Plug & Seal Length [mm] (L)					
			20	25	30	40	50	60
15.5	15	10	20	25	30	40	50	60
20.7	20	14	20	25	30	40	50	60
25.9	25	18	20	25	30	40	50	60
30.9	30	22	20	25	30	40	50	60
40.9	40	32	20	25	30	40	50	60

Wall thickness of base part (b):

1.0 mm (Plug & Seal for locating bore 15, 20, 25 mm)

1.5 mm (Plug & Seal for locating bore 30, 40 mm)

*Minimum compression of 15%

**Recommended values, depending on elastomer base material: steel (bonderised)

Delivery times for the individual dimensions are available on demand as the standard programme is currently in development (status 01/05). To ensure full functioning the specifications regarding the quality of the housing should be observed (see next page).

Selection of diverse materials and specifications for installation

If Plug & Seal is to offer a secure leakfree connection in practice, a number of outline conditions need to be fulfilled. This includes selection of the right elastomer for the application and the proper preparation of the housing.

Elastomers for a wide range of applications

For the selection and design of Plug & Seal a whole range of elastomers and base parts is offered (incl. steel, plastic, aluminium). The table shown below lists the elastomer materials available for the seals as well as the possible applications.

Specifications for quality of housing

- surface roughness R
 - static pressures: $R_{max} < 16 \mu\text{m}$,
 - pulsating pressures: $R_{max} < 6 \mu\text{m}$
- tolerance ISO H8
- recommended insertion angle:
 - chamfer of min. 20° ,
 - chamfer length (a) approx. 2 mm,
 - edges burr-free and rounded
- depth of housing (t1):
 - $> 7 \text{ mm}$
- max. axial offset as agreed

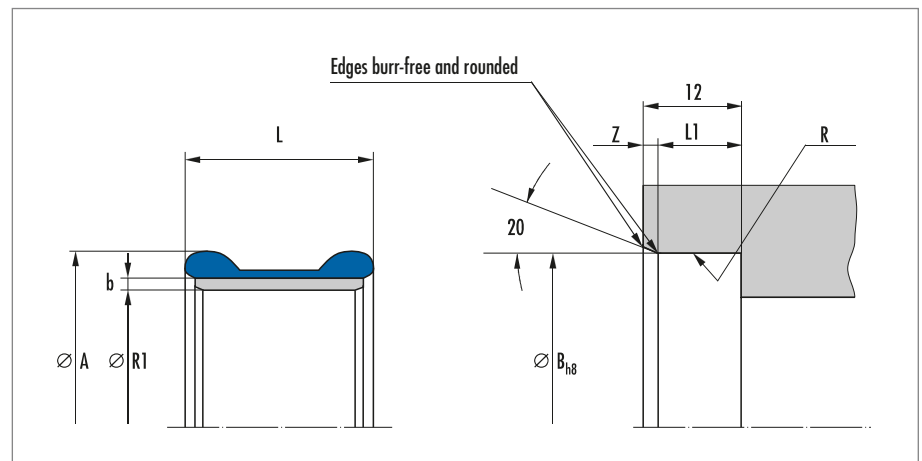

Wall thickness of base part (b):
 1.0 mm (Plug & Seal for locating bore 15, 20, 25 mm)
 1.5 mm (Plug & Seal for locating bore 30, 40 mm)

Plug & Seal materials and operating conditions for elastomer seal:

Elastomer	Media	Temperature		Possible applications
		from [°C]	to [°C]	
EPDM*	not oil-resistant	-40	+140	Cooling water, brake fluid, aqueous media
FKM*	oil-resistant	-10	+220	Charge air containing oil, cooling water, fuels such as diesel, biodiesel, motor fuel
VMQ	oil-resistant	-40	+220	Intake air, charge air containing oil
AEM	oil-resistant	-25	+150	Charge air containing oil, engine oil
ACM	oil-resistant	-25	+150	Engine oil
NBR	oil-resistant	-30	+90	Transmission oil
HNBR	oil-resistant	-30	+140	Transmission oil, engine oil, diesel fuel

*Standard materials

Simrit, Your Global Technology Specialist for Seals and Vibration Control

Simrit Services

- Constant innovations
- Uniquely wide range of products
- Strong product brands
- Unique materials expertise
- A wide range of value added services

Your Benefits

- Technological edge
- All from one source
- Specialised technological expertise
- Longer unit service life
- Competitive advantages, efficiency and lower costs

e. g. Plug & Seal: Fast-fit plug Connections for Housings, Pipe Ends and Assemblies

Your Benefits

- Seals for high pressure/structure-borne sound insulation
- Compensation for misalignment/offset in housing
- Simple low-cost fitting

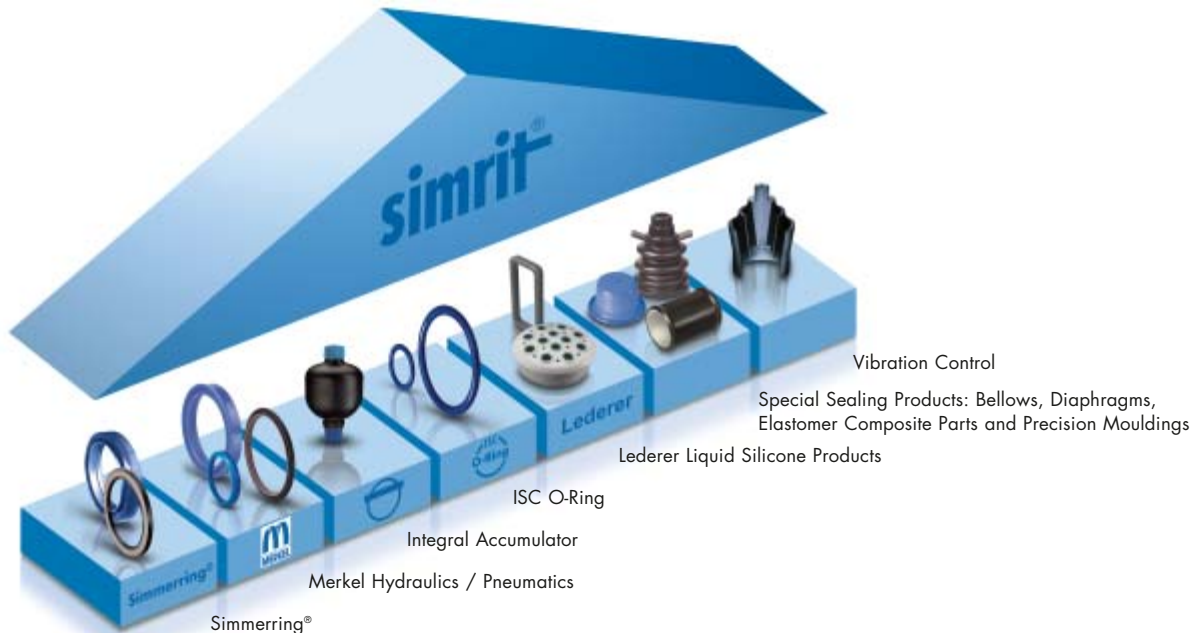

Headquarters Europe
Freudenberg Simrit KG
69465 Weinheim, Germany



Phone: +49 (0) 18 05-74 67 48
Fax: +49 (0) 18 03-74 67 48
e-mail: info@simrit.de
www.simrit.com

